

# HIKOKI

---

DV 22V

---

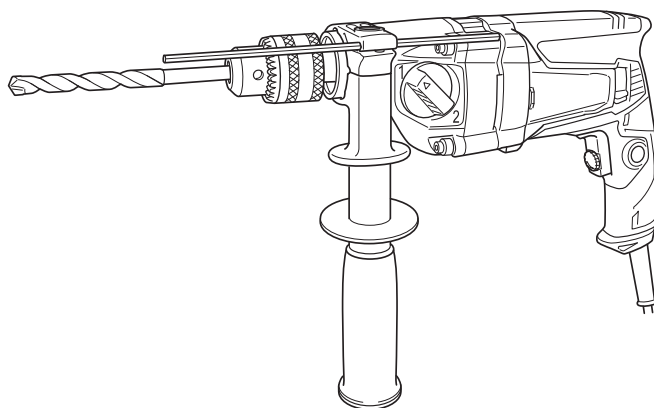

Handling instructions



## GENERAL POWER TOOL SAFETY WARNINGS

### WARNING

Read all safety warnings, instructions, illustrations and specifications provided with this power tool.

Failure to follow all instructions listed below may result in electric shock, fire and/or serious injury.

Save all warnings and instructions for future reference.

The term "power tool" in the warnings refers to your mains-operated (corded) power tool or battery-operated (cordless) power tool.

#### 1) Work area safety

- a) **Keep work area clean and well lit.**  
*Cluttered or dark areas invite accidents.*
- b) **Do not operate power tools in explosive atmospheres, such as in the presence of flammable liquids, gases or dust.**  
*Power tools create sparks which may ignite the dust or fumes.*
- c) **Keep children and bystanders away while operating a power tool.**  
*Distractions can cause you to lose control.*

#### 2) Electrical safety

- a) **Power tool plugs must match the outlet. Never modify the plug in any way. Do not use any adapter plugs with earthed (grounded) power tools.**  
*Unmodified plugs and matching outlets will reduce risk of electric shock.*
- b) **Avoid body contact with earthed or grounded surfaces, such as pipes, radiators, ranges and refrigerators.**  
*There is an increased risk of electric shock if your body is earthed or grounded.*
- c) **Do not expose power tools to rain or wet conditions.**  
*Water entering a power tool will increase the risk of electric shock.*
- d) **Do not abuse the cord. Never use the cord for carrying, pulling or unplugging the power tool. Keep cord away from heat, oil, sharp edges or moving parts.**  
*Damaged or entangled cords increase the risk of electric shock.*
- e) **When operating a power tool outdoors, use an extension cord suitable for outdoor use.**  
*Use of a cord suitable for outdoor use reduces the risk of electric shock.*
- f) **If operating a power tool in a damp location is unavoidable, use a residual current device (RCD) protected supply.**  
*Use of an RCD reduces the risk of electric shock.*

#### 3) Personal safety

- a) **Stay alert, watch what you are doing and use common sense when operating a power tool. Do not use a power tool while you are tired or under the influence of drugs, alcohol or medication.**  
*A moment of inattention while operating power tools may result in serious personal injury.*
- b) **Use personal protective equipment. Always wear eye protection.**  
*Protective equipment such as a dust mask, non-skid safety shoes, hard hat or hearing protection used for appropriate conditions will reduce personal injuries.*

- c) **Prevent unintentional starting. Ensure the switch is in the off-position before connecting to power source and/or battery pack, picking up or carrying the tool.**

*Carrying power tools with your finger on the switch or energising power tools that have the switch on invites accidents.*

- d) **Remove any adjusting key or wrench before turning the power tool on.**  
*A wrench or a key left attached to a rotating part of the power tool may result in personal injury.*
  - e) **Do not overreach. Keep proper footing and balance at all times.**  
*This enables better control of the power tool in unexpected situations.*
  - f) **Dress properly. Do not wear loose clothing or jewellery. Keep your hair and clothing away from moving parts.**  
*Loose clothes, jewellery or long hair can be caught in moving parts.*
  - g) **If devices are provided for the connection of dust extraction and collection facilities, ensure these are connected and properly used.**  
*Use of dust collection can reduce dust-related hazards.*
  - h) **Do not let familiarity gained from frequent use of tools allow you to become complacent and ignore tool safety principles.**  
*A careless action can cause severe injury within a fraction of a second.*
- #### 4) Power tool use and care
- a) **Do not force the power tool. Use the correct power tool for your application.**  
*The correct power tool will do the job better and safer at the rate for which it was designed.*
  - b) **Do not use the power tool if the switch does not turn it on and off.**  
*Any power tool that cannot be controlled with the switch is dangerous and must be repaired.*
  - c) **Disconnect the plug from the power source and/or remove the battery pack, if detachable, from the power tool before making any adjustments, changing accessories, or storing power tools.**  
*Such preventive safety measures reduce the risk of starting the power tool accidentally.*
  - d) **Store idle power tools out of the reach of children and do not allow persons unfamiliar with the power tool or these instructions to operate the power tool.**  
*Power tools are dangerous in the hands of untrained users.*
  - e) **Maintain power tools and accessories. Check for misalignment or binding of moving parts, breakage of parts and any other condition that may affect the power tool's operation. If damaged, have the power tool repaired before use.**  
*Many accidents are caused by poorly maintained power tools.*
  - f) **Keep cutting tools sharp and clean.**  
*Properly maintained cutting tools with sharp cutting edges are less likely to bind and are easier to control.*
  - g) **Use the power tool, accessories and tool bits etc. in accordance with these instructions, taking into account the working conditions and the work to be performed.**  
*Use of the power tool for operations different from those intended could result in a hazardous situation.*

h) **Keep handles and grasping surfaces dry, clean and free from oil and grease.**

*Slippery handles and grasping surfaces do not allow for safe handling and control of the tool in unexpected situations.*

5) **Service**

a) **Have your power tool serviced by a qualified repair person using only identical replacement parts.**

*This will ensure that the safety of the power tool is maintained.*

**PRECAUTION**

**Keep children and infirm persons away. When not in use, tools should be stored out of reach of children and infirm persons.**

**IMPACT DRILL SAFETY WARNINGS**

**Safety instructions for all operations**

a) **Wear ear protectors when impact drilling.**

*Exposure to noise can cause hearing loss.*

b) **Use the auxiliary handle(s).**

*Loss of control can cause personal injury.*

c) **Hold the power tool by insulated gripping surfaces, when performing an operation where the cutting accessory may contact hidden wiring or its own cord.**

*Cutting accessory contacting a "live" wire may make exposed metal parts of the power tool "live" and could give the operator an electric shock.*

**Safety instructions when using long drill bits**

a) **Never operate at higher speed than the maximum speed rating of the drill bit.**

*At higher speeds, the bit is likely to bend if allowed to rotate freely without contacting the workpiece, resulting in personal injury.*

b) **Always start drilling at low speed and with the bit tip in contact with the workpiece.**

*At higher speeds, the bit is likely to bend if allowed to rotate freely without contacting the workpiece, resulting in personal injury.*

c) **Apply pressure only in direct line with the bit and do not apply excessive pressure.**

*Bits can bend causing breakage or loss of control, resulting in personal injury.*

**ADDITIONAL SAFETY WARNINGS**

1. Make sure to securely hold the tool during operation. Failure to do so can result in accidents or injuries (Fig. 1).

2. Ensure that the power source to be utilized conforms to the power requirements specified on the product nameplate.

3. Ensure that the power switch is in the OFF position. If the plug is connected to a receptacle while the power switch is in the ON position, the power tool will start operating immediately, which could cause a serious accident.

4. When the work area is removed from the power source, use an extension cord of sufficient thickness and rated capacity. The extension cord should be kept as short as practicable.

5. **Drilling**

○ When drilling, start the impact drill slowly, and gradually increasing speed as you impact drill.

○ Always apply pressure in a straight line with the bit. Use enough pressure to keep drilling, but do not push hard enough to stall the motor or deflect the bit.

○ To minimize stalling or breaking through the material, reduce pressure on drill and ease the bit through the last part of the hole.

○ If the impact drill stalls, release the trigger immediately, remove the bit from the work and start again. Do not click the trigger on and off in an attempt to start a stalled impact drill. This can damage the impact drill.

○ The larger the drill bit diameter, the larger the reactive force on your arm.

*Be careful not to lose control of the impact drill because of this reactive force.*

*To maintain firm control, establish a good foothold, use side handle, hold the impact drill tightly with both hands, and ensure that the impact drill is vertical to the material being drilled.*

○ **Precautions on boring**

*The drill bit may become overheated during operation; however, it is sufficiently operable. Do not cool the drill bit in water or oil.*

○ **Caution concerning immediately after use**

*Immediately after use, while it is still revolving, if the impact drill is placed on a location where considerable ground chips and dust have accumulated, dust may occasionally be absorbed into the drill mechanism. Always pay attention to this undesirable possibility.*

6. **Check the rotational direction**

○ **Actuate the rotational change lever only when the machine is at a standstill.**

*The rotational change lever is used to reverse the rotational direction of the machine.*

*However, this is not possible with the On/Off switch actuated.*

○ **Operating the tool with the rotational change lever in mid-position may result in damage.**

*When switching, make sure that you shift the rotational change lever to the correct position.*

○ **Always use the impact drill with clockwise rotation, when using it as an impact drill.**

7. **IMPACT to ROTATION changeover**

○ **Do not use the impact drill in the IMPACT mode if the material can be bored by rotation only. Such action will not only reduce drill efficiency, but may also damage the drill tip.**

○ **Operating the impact drill with the change lever in mid-position may result in damage. When switching, make sure that you shift the change lever to the correct position.**







8. **RCD**









*The use of a residual current device with a rated residual current of 30 mA or less at all times is recommended.*

**SYMBOLS**

**WARNING**

**The following show symbols used for the machine. Be sure that you understand their meaning before use.**

	DV22V: Impact Drill
	To reduce the risk of injury, user must read instruction manual.
	Rated voltage
	Power Input
	No-load speed
	Rotation only function
	Rotation and impact function

	Concrete
	Switching ON
	Switching OFF
	Change
	Change rotation speed - Low speed
	Clockwise rotation
	Counterclockwise rotation
	Disconnect mains plug from electrical outlet
	Class II tool

## MOUNTING AND OPERATION

Action	Figure	Page
Insulated gripping surface	1	5
Fixing and removing side handle	2	5
Using depth stopper	3	5
Mounting and dismounting of the bit	4	5
Selecting rotation direction	5	6
Selecting the operating mode	6	6
Switch operation	7	6
Change rotation speed	8	7
Selecting accessories	—	8

### Selecting the appropriate drill bit

- When boring concrete or stone  
Use the drill bits specified in the Optional Accessories.
- When boring metal or plastic  
Use an ordinary metalworking drill bit.
- When boring wood  
Use ordinary woodworking drill bit.  
However, when drilling 6.5 mm or smaller holes, use a metalworking drill bit.



## STANDARD ACCESSORIES

In addition to the main unit (1 unit), the package contains the accessories listed in the below.

- (1) Chuck wrench (Spec. only for keyed chuck) ..... 1
- (2) Side handle ..... 1
- (3) Depth gauge ..... 1
- (4) Plastic case ..... 1

Standard accessories are subject to change without notice.

## APPLICATIONS

- By combined actions of ROTATION and IMPACT:   
Boring holes in hard materials (concrete, marble, granite, tiles, etc.)
- By ROTATIONAL action:   
Boring holes in metal, wood and plastic.

## SPECIFICATIONS

Voltage*	(110 V, 220 V, 230 V, 240 V) ~		
Power input	1120 W*		
Speed range	1	2	
No load speed	0 – 1100 /min	0 – 3000 /min	
Capacity	Steel	16 mm	8 mm
	Concrete	22 mm	13 mm
	Wood	40 mm	25 mm
Full-load impact rate	8100 /min	22000 /min	
Weight	3.0 kg		

\* Be sure to check the nameplate on product as it is subject to change by areas.

### NOTE

Due to HiKOKI's continuing program of research and development, the specifications herein are subject to change without prior notice.

## MAINTENANCE AND INSPECTION

### 1. Inspecting the drill bits

Since use of an abraded drill bits will cause motor malfunctioning and degraded efficiency, replace the drill bits with a new one or resharpening without delay when abrasion is noted.

### 2. Inspecting the mounting screws

Regularly inspect all mounting screws and ensure that they are properly tightened. Should any of the screws be loose, retighten them immediately. Failure to do so could result in serious hazard.

### 3. Maintenance of the motor

The motor unit winding is the very "heart" of the power tool. Exercise due care to ensure the winding does not become damaged and/or wet with oil or water.

### 4. Inspecting the carbon brushes

For your continued safety and electrical shock protection, carbon brush inspection and replacement on this tool should ONLY be performed by a HiKOKI Authorized Service Center.

### 5. Replacing supply cord

If the replacement of the supply cord is necessary, it has to be done by HiKOKI Authorized Service Center to avoid a safety hazard.

### CAUTION

In the operation and maintenance of power tools, the safety regulations and standards prescribed in each country must be observed.

### NOTE

Due to HiKOKI's continuing program of research and development, the specifications herein are subject to change without prior notice.

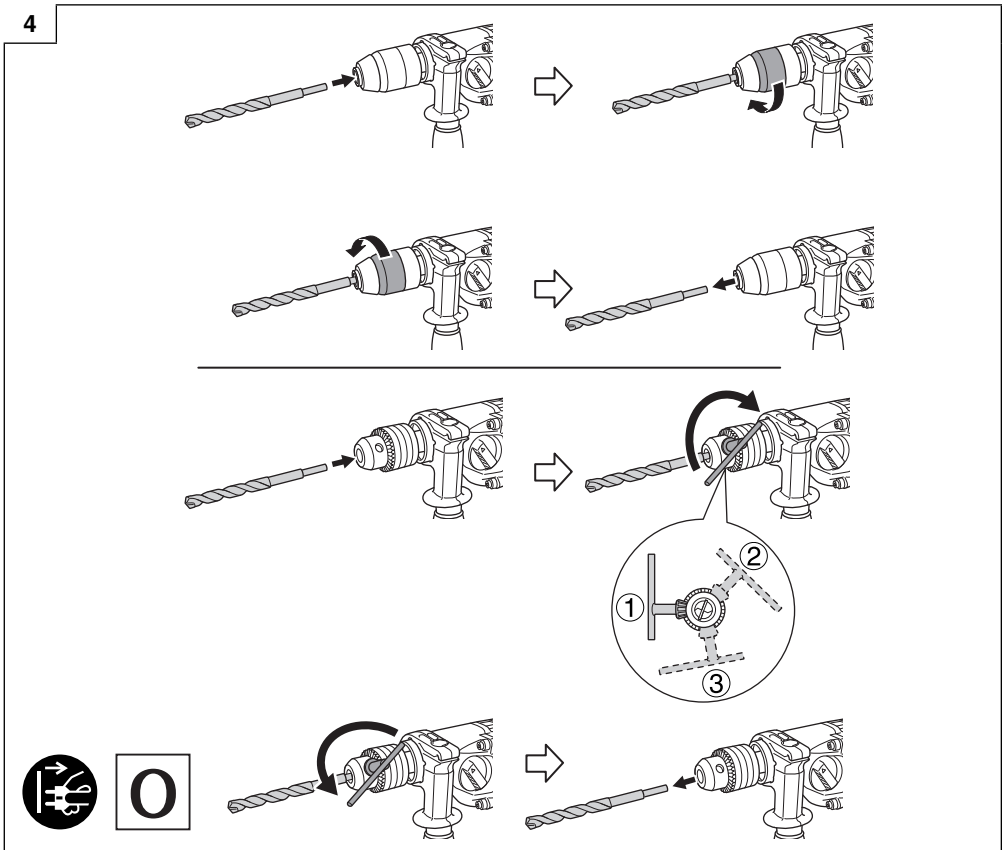
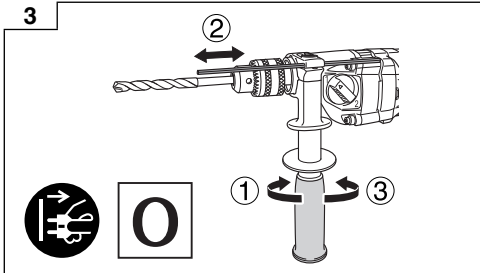
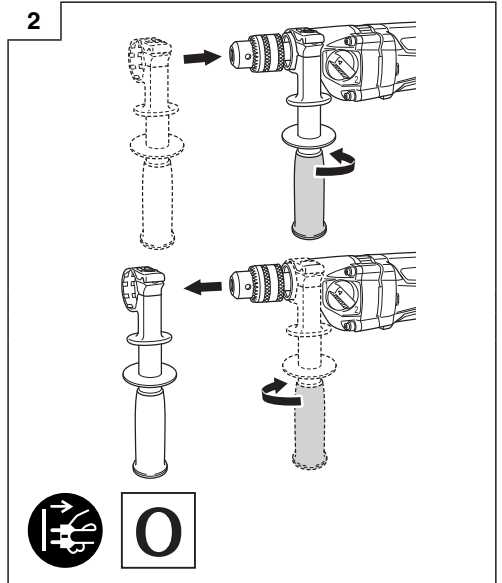
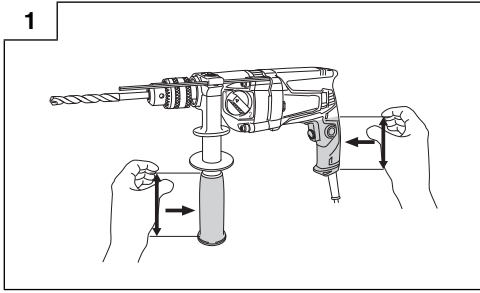

5

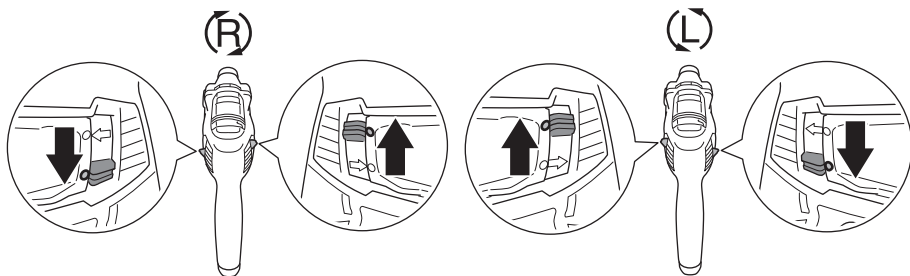

O

6

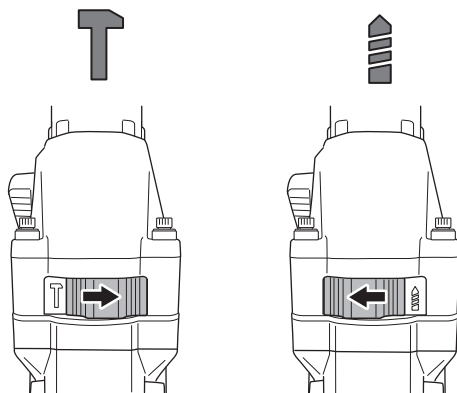

O

7

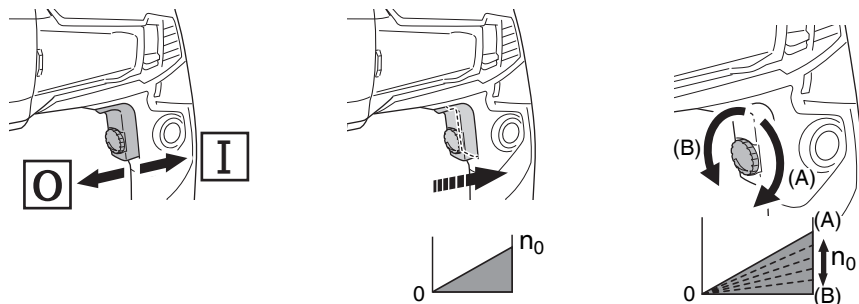

8

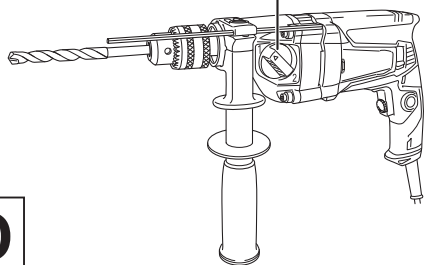
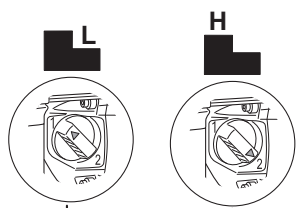

O

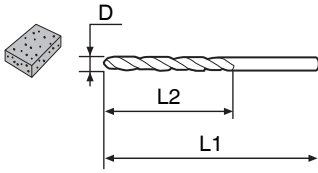

(mm)			
D	L1	L2	
3.2	65	35	939875
4.8	85	40	939879
5.5	100	65	939882
6.4	100	65	939884
8.0	100	65	931852
10.0	120	70	931854
12.0	120	70	971704
13.0	160	110	931855
14.3	160	110	931776
16.0	160	110	971670

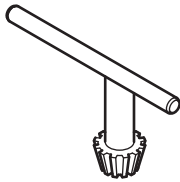

987576

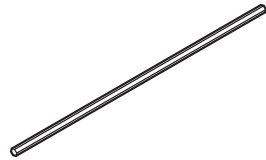

303709

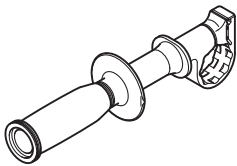

338768

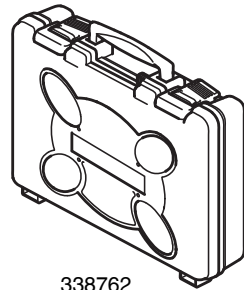

338762



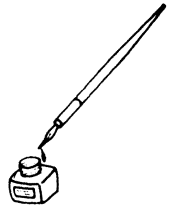

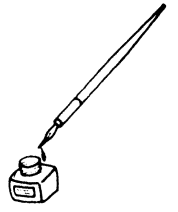

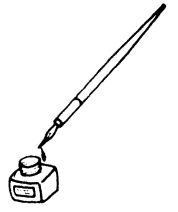

# Koki Holdings Co., Ltd.

Shinagawa Intercity Tower A, 15-1, Konan 2-chome,  
Minato-ku, Tokyo, Japan