

PRESA DI FORZA A COMANDO PNEUMATICO

PNEUMATIC CLUTCH POWER TAKE-OFF

CODICE PTO
PTO CODE

72-92

CAMBIO
GEARBOX

ISUZU

Codice foglio: 997-272-09213 Rev: AA



DIAGRAMMA DI UTILIZZO WORKING CONDITION

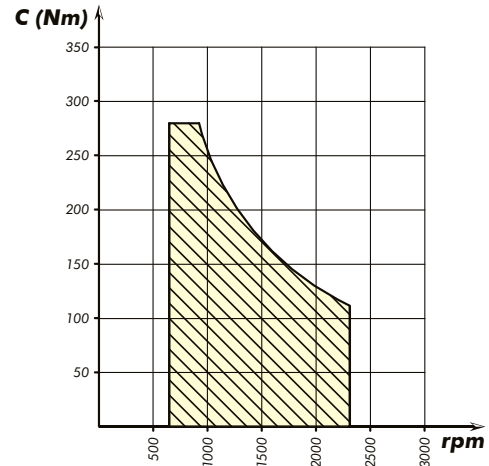

Rev: //

Codice fascicolo:

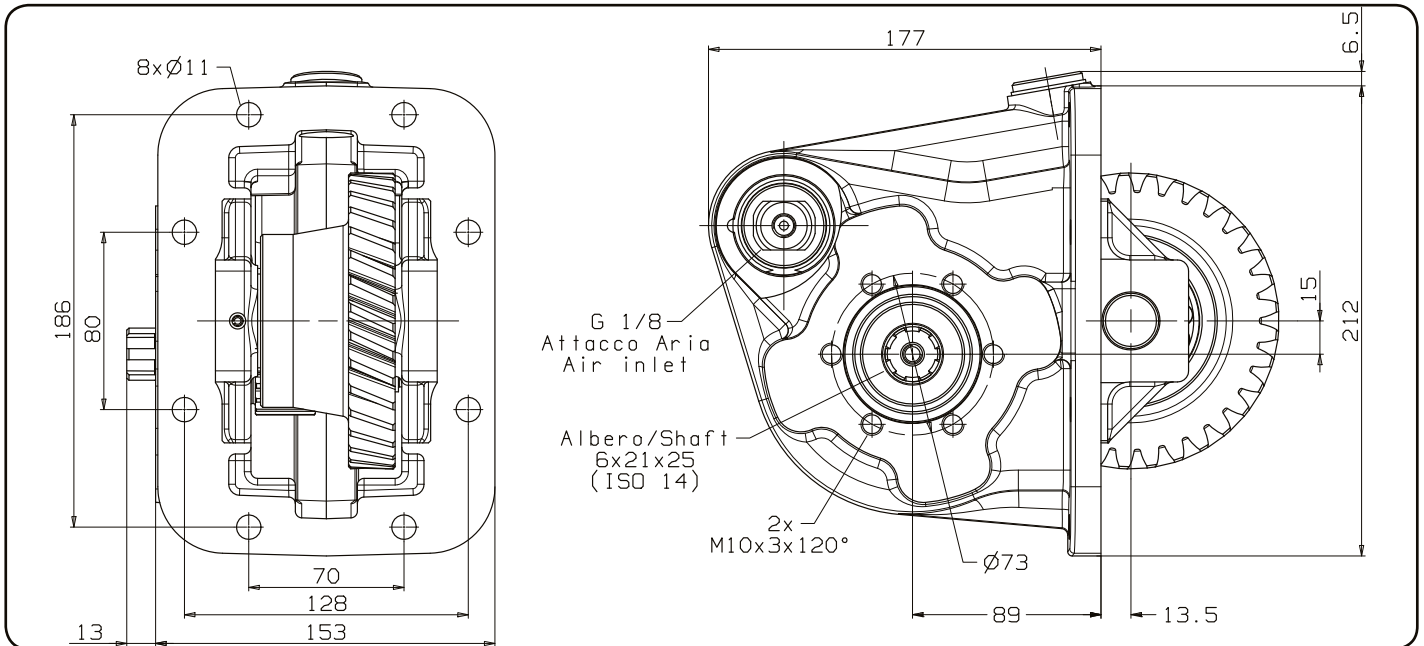

Data: Martedì 30 giugno 2009

Tipo cambio Gearbox	Codice PTO PTO code	Versione Version	Giri pto a 1000 giri motore Pto ratio@1000 eng.rpm	Coppia massima Max torque	Lato montaggio Mounting side	Uscita Output	Rotazione Rotation	Kit di montaggio Mounting kit
			rpm	Nm				
MLD 6E / 7R (Z34)	72-92-133	13	6E-7R=831	280	Sx Left	Poster. Rear	Orar. Cw	154-3-3464
MLD 6S (Z36)			6S=1143					154-0-0568
MLD 6Q/6W (Z36)			6Q-6W=1073					

pag.1