

# PRESA DI FORZA A COMANDO ELETTROMAGNETICO ELECTROMAGNETIC CLUTCH POWER TAKE-OFF

**CODICE PTO**  
PTO CODE

**71-578**

**CAMBIO**  
GEARBOX

**ISUZU**

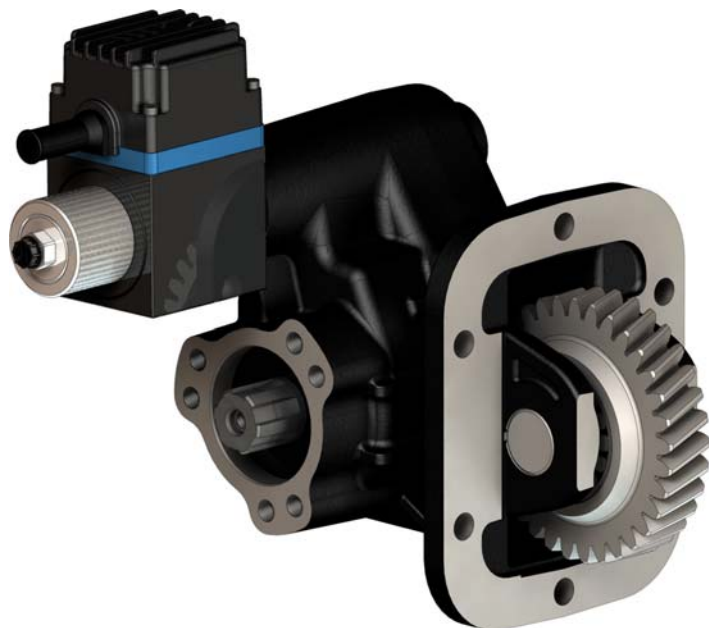

## DIAGRAMMA DI UTILIZZO WORKING CONDITION

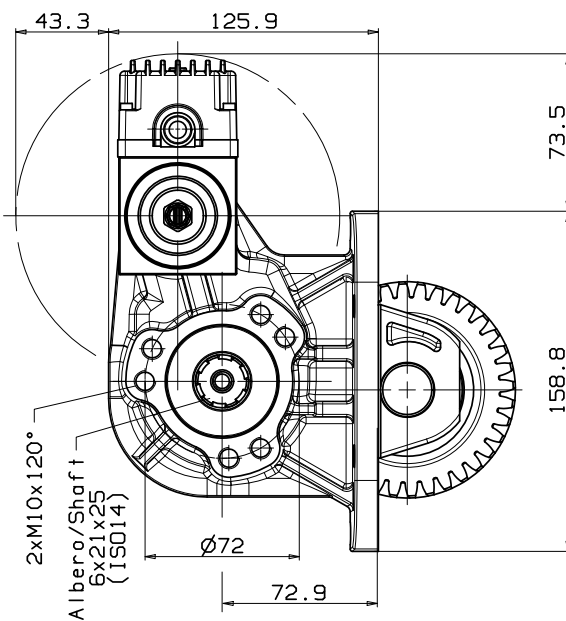
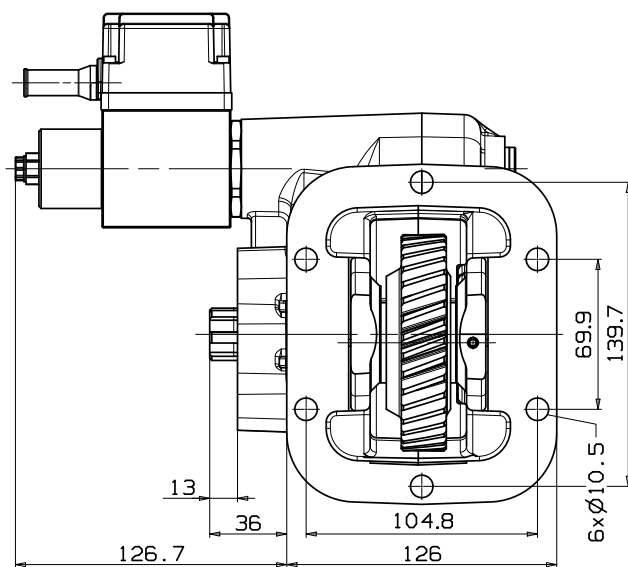
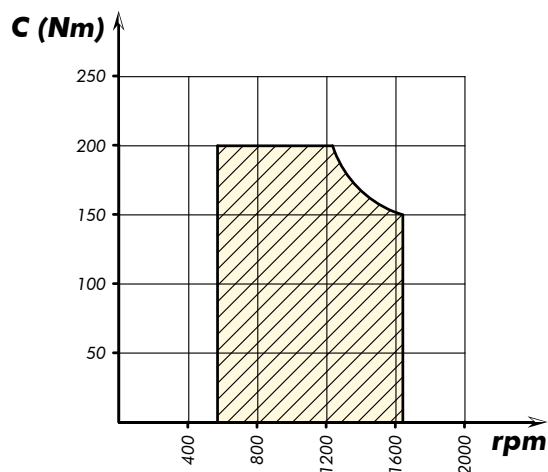

Tipo cambio Gearbox	Codice PTO PTO code	Versione Version	Giri pto a 1000 giri motore Pto ratio@1000 eng.rpm	Coppia massima Max torque	Lato montaggio Mounting side	Uscita Output	Rotazione Rotation	Kit di montaggio Mounting kit	Peso Weight
			rpm	Nm					Kg
<b>MYY-5T/5,315</b>	<b>71-578-10136</b>	13	821	<b>200</b>	Sx Left	Poster. Rear	Orar. Cw	154-3-3240	10,7
<b>MYY-6P/5,979</b>			730						
<b>MYY-6S/5,979</b>									

pag.1