

PRESA DI FORZA A COMANDO PNEUMATICO

PNEUMATIC CLUTCH POWER TAKE-OFF

CODICE PTO
PTO CODE

052-009-08138

CAMBIO
GEARBOX

EATON

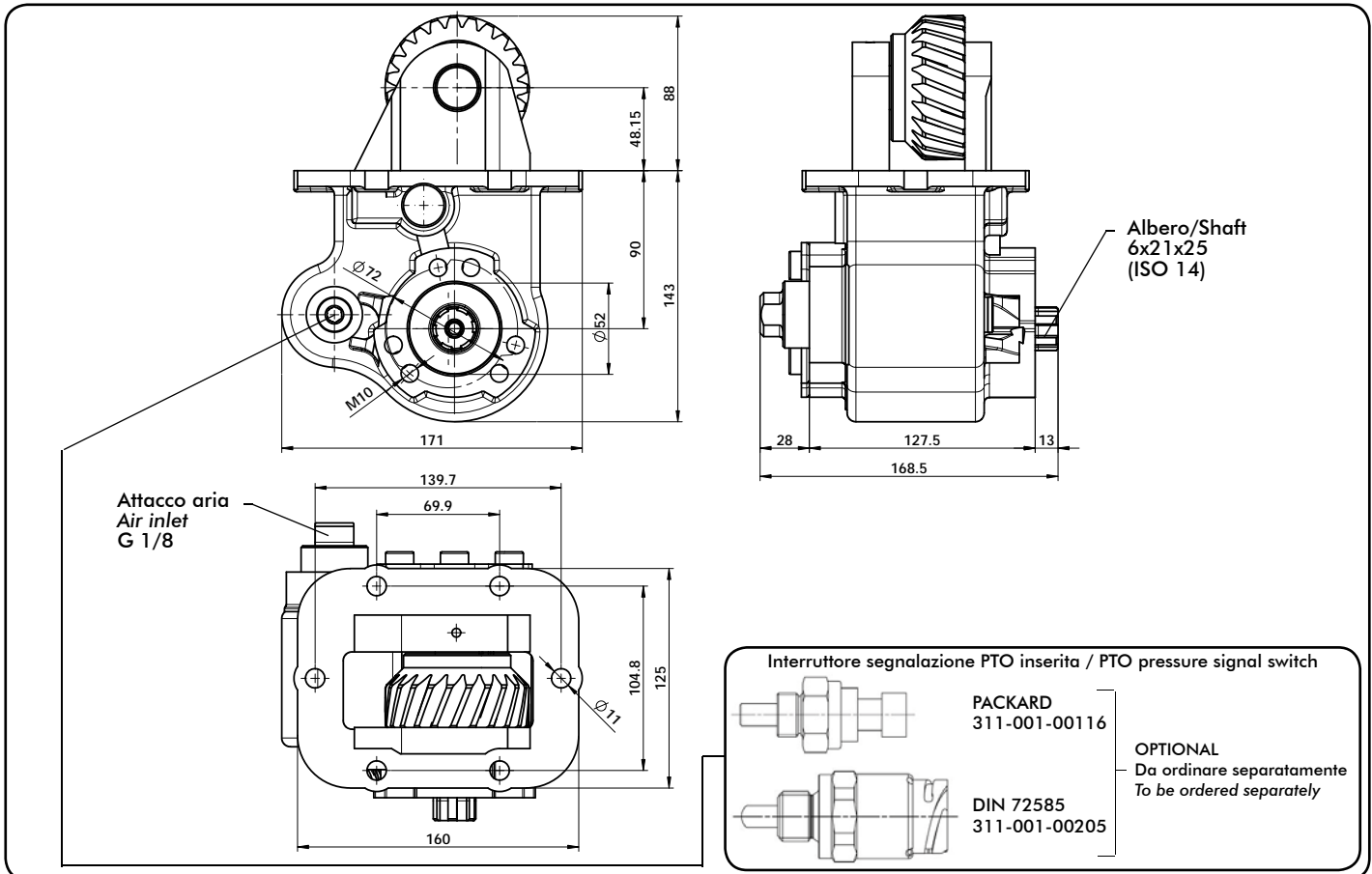
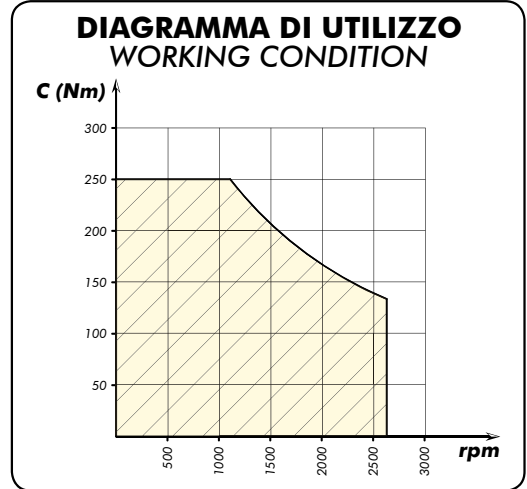
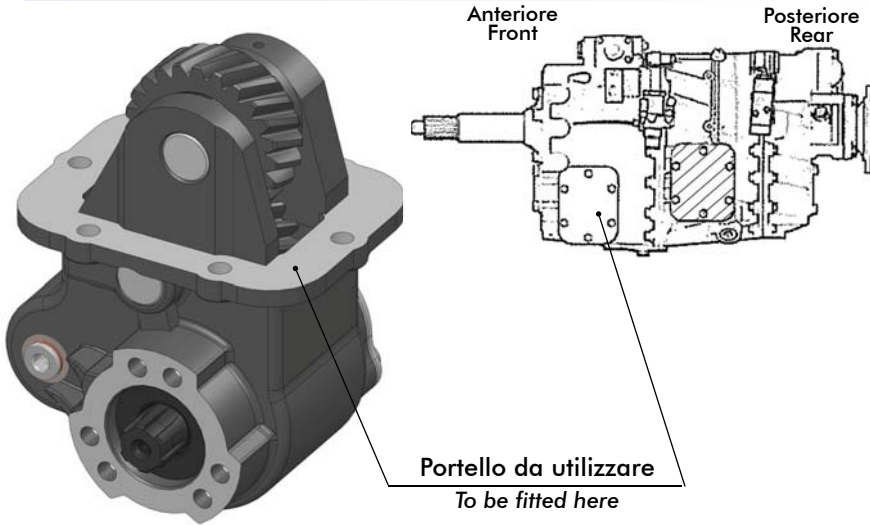

Tipo cambio Gearbox	Codice PTO PTO code	Versione Version	Giri pto a 1000 giri motore Pto ratio@1000 eng.rpm rpm	Coppia massima Max torque Nm	Lato montaggio Mounting side	Uscita Output	Rotazione Rotation	Kit di montaggio Mounting kit	Peso Weight Kg
FS-6109/6209 6309/8209/8309	052-009-08138	813	1227	250	Sx Left	Post. Rear	Ant. Acw	154-3-3286	11,3
ES-11109 ES-11209									