

# PRESA DI FORZA A COMANDO ELETTROMAGNETICO ELECTROMAGNETIC CLUTCH POWER TAKE-OFF

**CODICE PTO**  
PTO CODE

**1-564**

**CAMBIO**  
GEARBOX

**ZF**

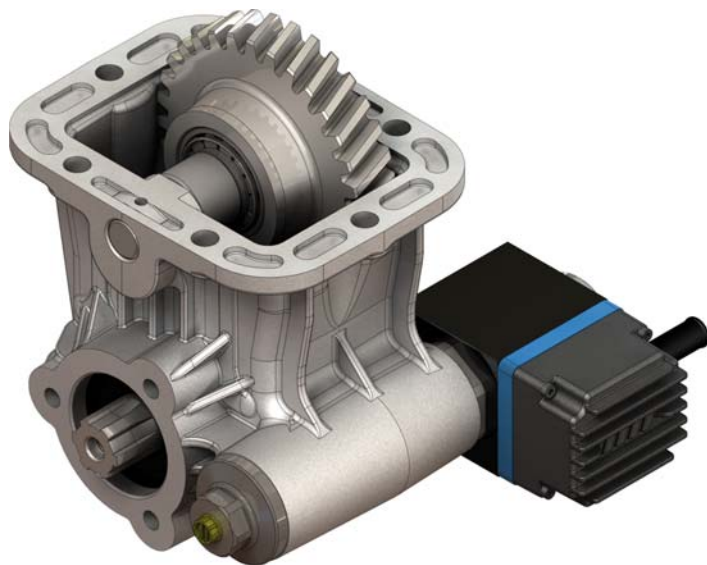

## DIAGRAMMA DI UTILIZZO

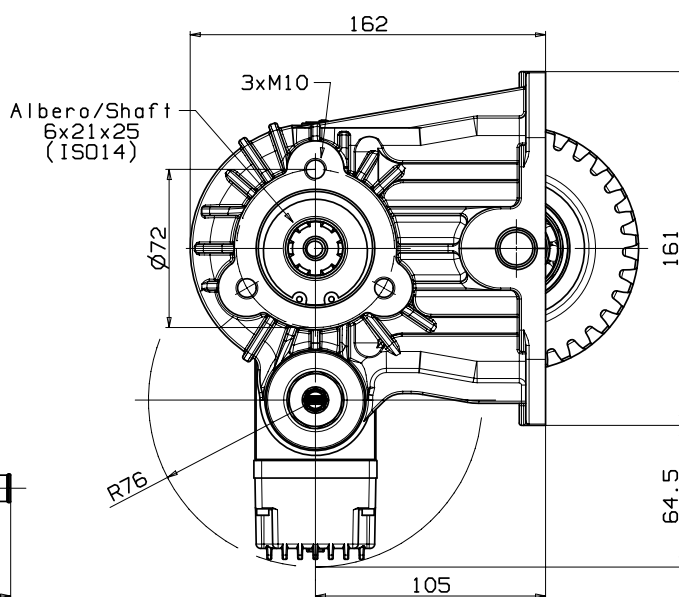
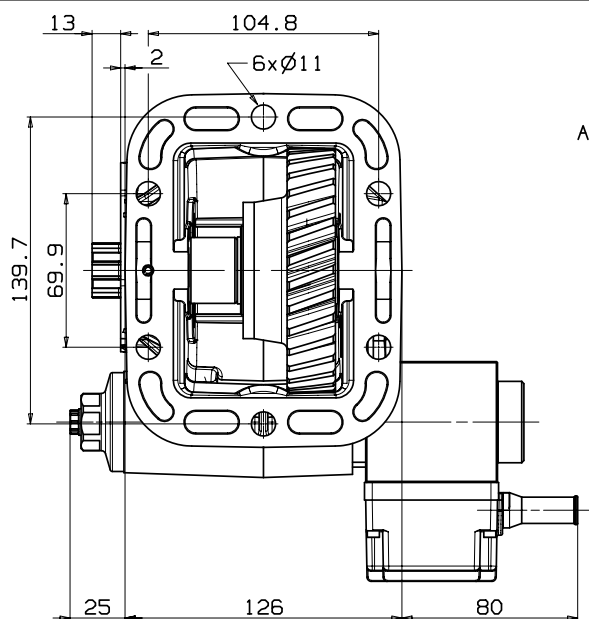
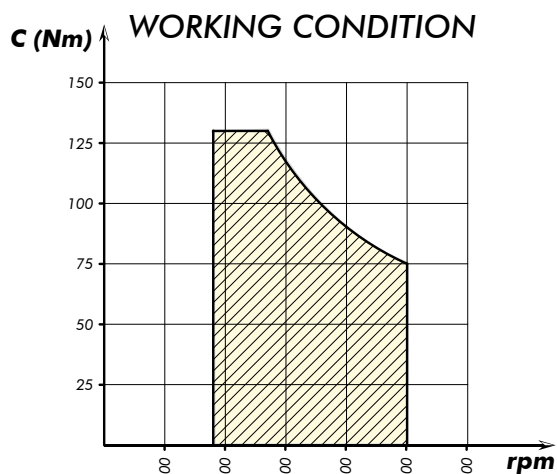

Data: Mercoledì 16 novembre 2016

Codice foglio: 997-201-56412 Rev: AA

Tipo cambio Gearbox	Codice PTO PTO code	Versione Version	Giri pto a 1000 giri motore Pto ratio@1000 eng.rpm	Coppia massima Max torque	Lato montaggio Mounting side	Uscita Output	Rotazione Rotation	Kit di montaggio Mounting kit	Peso Weight
			rpm	Nm					Kg
<b>ZF 6S-380</b>	<b>1-564-10139</b>	13	1000	<b>130</b>	Dx Right	Poster. Rear	Orar. Cw	154-3-3133	8,5
<b>ZF 6S-380 VO/5,38</b>									
<b>ZF 6S-400V/5,375</b>									
<b>ZF 6S-400/5,375</b>									
<b>ZF 6S-420V/5,779</b>									
<b>ZF 6AS-400/5,375</b>									
<b>IVECO 2840.6/5,4</b>									

pag.1

**OMFB**  
HYDRAULIC COMPONENTS

O.M.F.B. S.p.A. Hydraulic Components  
We reserve the right to make any changes without notice.  
Edition 2008.03 No reproduction, however partial, is permitted.  
Via Cave, 7/9 25050 Provaglia d'Iseo (Brescia) Italy Tel.: +39.030.9830611  
Fax: +39.030.9839207-208 Internet:www.omfb.it e-mail:info@omfb.it

COMPANY WITH  
QUALITY SYSTEM  
CERTIFIED BY DNV GL  
= ISO 9001 =