

**PRESA DI FORZA A
COMANDO PNEUMATICO
PNEUMATIC CLUTCH
POWER TAKE-OFF**

CODICE PTO
PTO CODE

072-094-00177

CAMBIO
GEARBOX

ISUZU

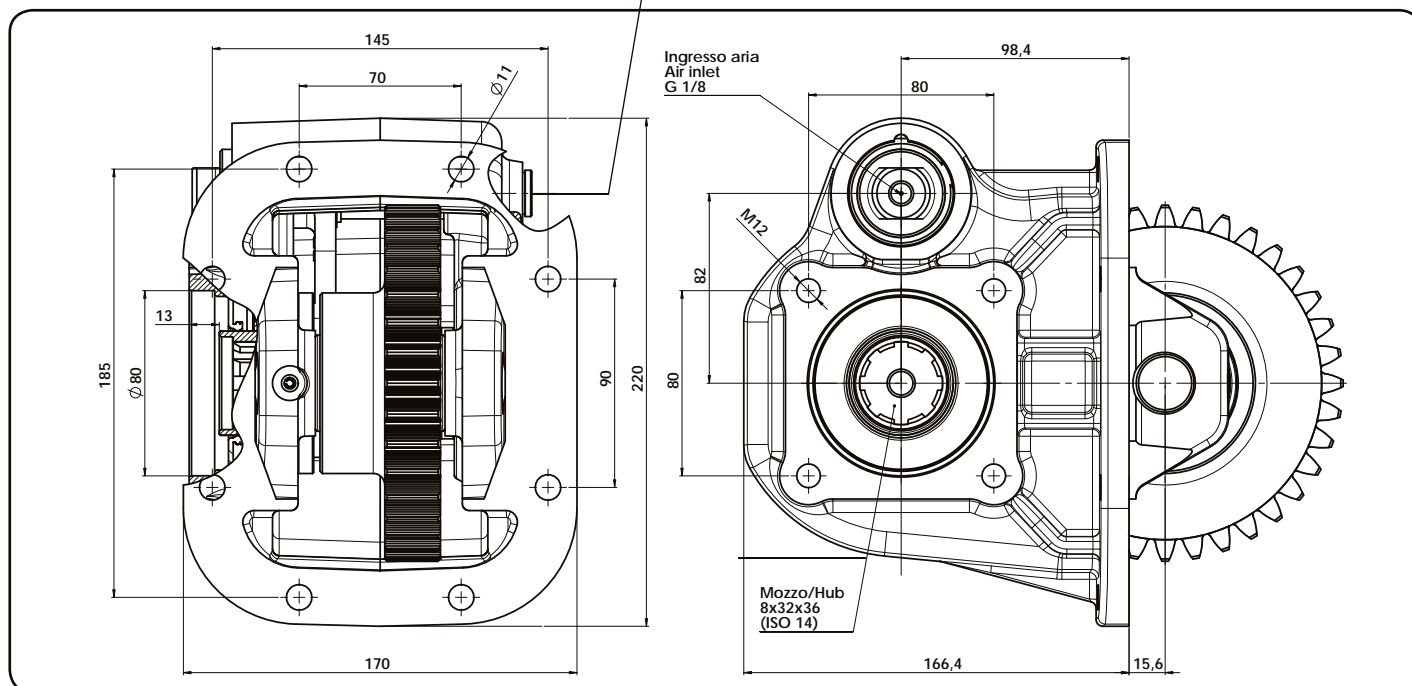
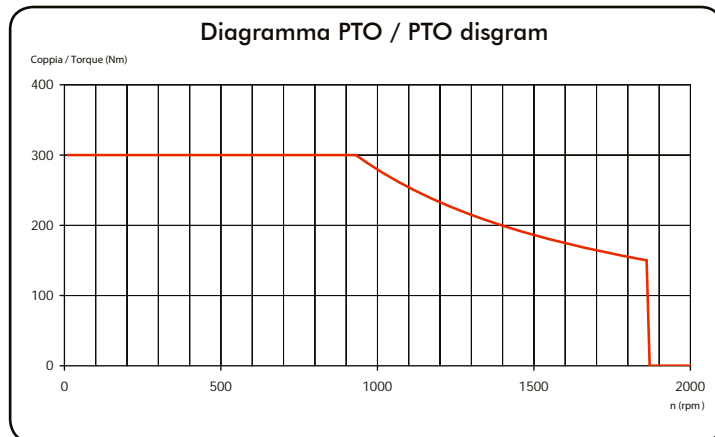
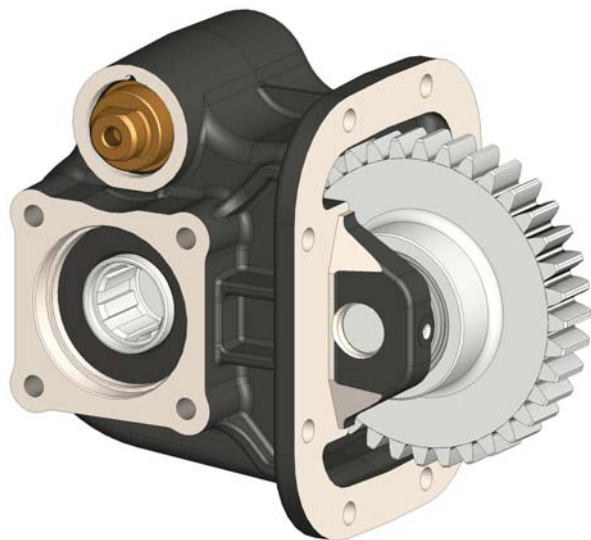

Tipo cambio Gearbox	Codice PTO PTO code	Versione Version	Giri pto a 1000 giri motore Pto ratio@1000 eng.rpm rpm	Coppia massima Max torque Nm	Lato montaggio Mounting side	Uscita Output	Rotazione Rotation	Kit di montaggio Mounting kit
MAL-MAG MJA	072-094-00177	17	931	300	Sx. Left	Poster. Rear	Orar. Cw	154-003-03160